

Latham Roof-Line Series Aluminium Expansion Joint Cover

FW

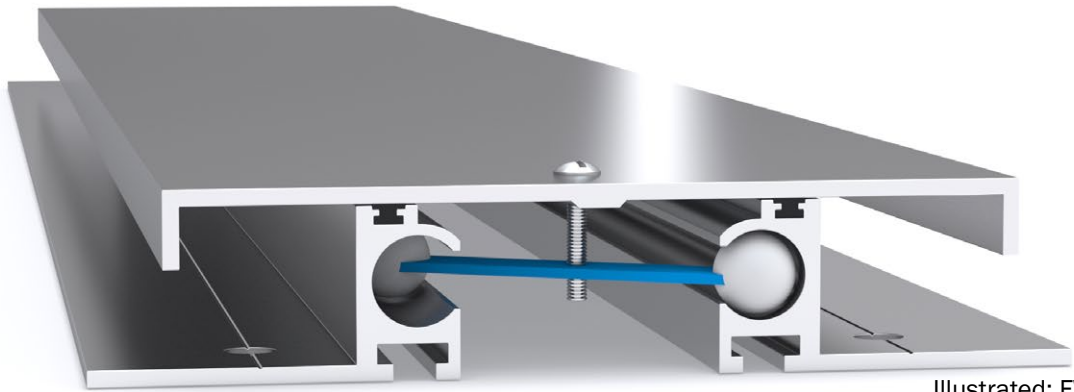

Illustrated: FW-50

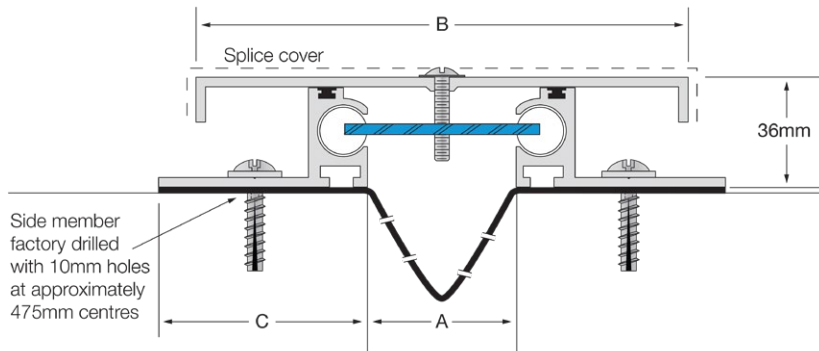

Aluminium Code	A	B	C	Movement	Total Available Movement	Overall Depth
FW-25	25	114	70	+25/-17mm	43mm	36mm
FW-50	50	165	70	+50/-43mm	92mm	36mm
FW-75	75	190	70	+50/-67mm	117mm	36mm
FW-100	100	215	70	+50/-92mm	142mm	36mm
FW-150	150	266	70	+50/-142mm	192mm	36mm

FEATURES

- Shallow aluminium roof expansion joint cover.
- Designed for installation on flat concrete or timber hobs, plinths or concrete roofs.
- Comes with standard water/wind barrier and top seal gaskets for the centre plate screw.
- Supplied with 1 splice plate per full length for installation over the junction between 2 plates to maintain water tightness.

MATERIALS

- Aluminium 6063-T5 mill finish alloy.
- Supplied in 3050mm lengths.
- Spring steel treated centering bar with nylon spherical balls (at ~475mm centres).

FIXINGS

- Side member pre-drilled at ~475mm centres for 10mm fasteners.
- End Closures, Transition Splices, Corners and Tees should be considered for roof joints. (Contact a Latham representative for more information)

FURTHER TECHNICAL SPECIFICATIONS

- [Website Link - PDF and DWG Details](#)
- [Product Information](#)
- [Joint Specifications](#)
- [Fire Rated Systems](#)
- [Full Product Catalogue](#)
- [Architectural Specifications](#)
- [Warranty](#)



multi directional
6-way movement



outdoor use



BFG water
gutter



fire rated (joint
widths >50mm)