

# Latham Heavy Duty Series Aluminium Expansion Joint Cover with Stainless Steel Cover Plate EHDF

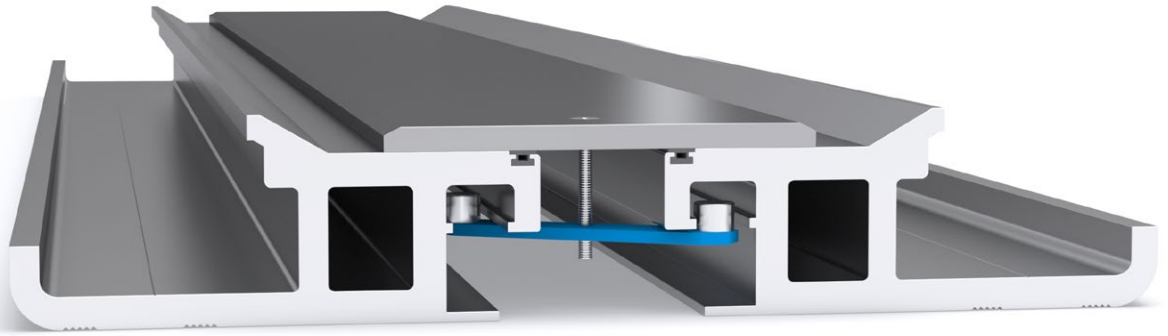

Illustrated: EHDF-50

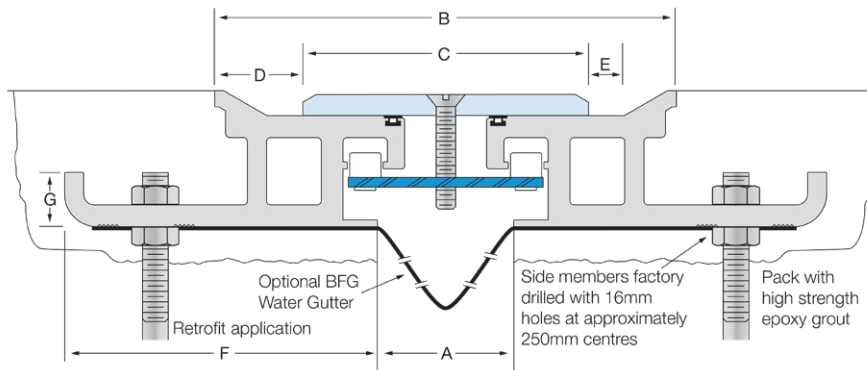

Stainless Steel Code	A	B	C	D	E	F	G	Movement	Total Available Movement	Overall Depth	Cover Plate Thickness	Maximum Coverplate Point Loading (kg)
EHDF-50	50	170	105	32	12	115	20	+25/-18mm	43mm	50mm	8mm	2310
EHDF-75	75	195	130	32	12	115	20	+/-25mm	50mm	50mm	8mm	1440
EHDF-100	100	220	155	32	12	115	20	+/-25mm	50mm	50mm	10mm	1580
EHDF-150	150	270	205	32	12	115	20	+/-25mm	50mm	50mm	10mm	1120

## FEATURES

- Aluminium floor expansion joint cover with a stainless steel cover plate.
- Designed for areas of heavy vehicular traffic.
- Joint can withstand impact and vibration generated by vehicular traffic travelling at speeds up to 20 kph.
- Installed in a pre-formed recess, in conjunction with mechanical fixings.

## MATERIALS

- Aluminium 6063-T5 mill finish alloy.
- 304 Grade, 2B finish stainless steel cover plates.
- Spring steel treated centering bar with elongated spherical rods (at ~475mm centres).
- Supplied in 3050mm lengths.

## FIXINGS

- Side members pre-drilled with 16mm holes at ~250mm centres.
- Should be packed with high strength epoxy grout.

## FURTHER TECHNICAL SPECIFICATIONS

- [Website Link - PDF and DWG Details](#)
- [Product Information](#)
- [Joint Specifications](#)
- [Fire Rated Systems](#)
- [Full Product Catalogue](#)
- [Architectural Specifications](#)
- [Warranty](#)

Contact a Latham Representative before, specifying with details of maximum loading, wheel diameter, width and type.

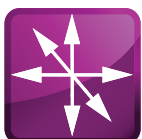

multi directional  
6-way movement



indoor & out-  
door use



BFG water  
gutter



fire rated (joint  
widths >50mm)



vehicular